

MAX. PROJECTED LUMINAIRE SAIL AREA = 2.5MSQ
 (BASED ON SYMMETRICAL LUM. ARRANGEMENT)
 MAX. LUMINAIRE AND BALLAST/COUNTER WEIGHT MASS = 800KGS

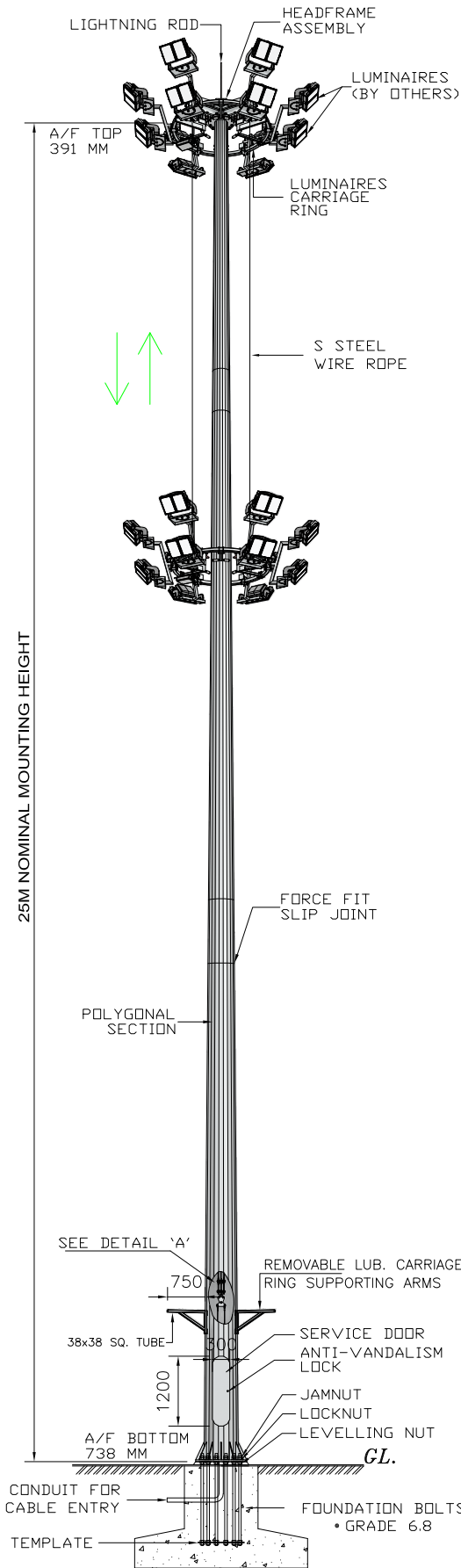

HEADFRAME

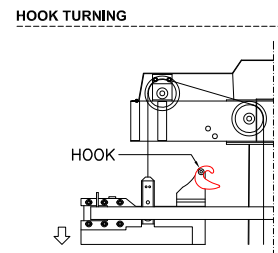
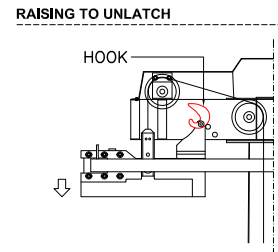
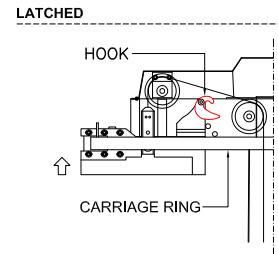
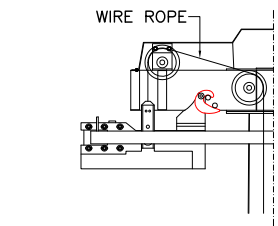

UNLATCH & LOWERED

SERVICE DOOR

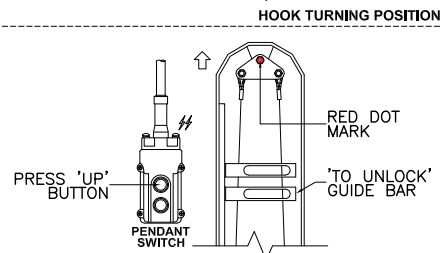
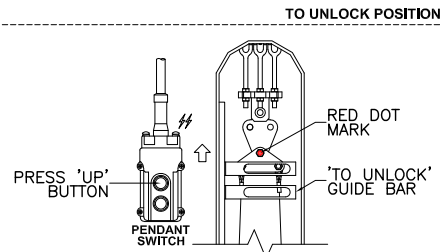
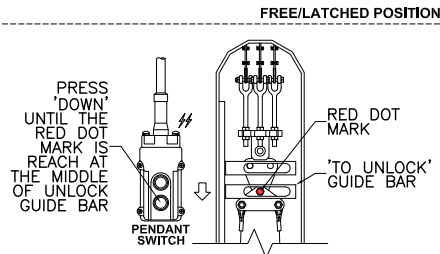
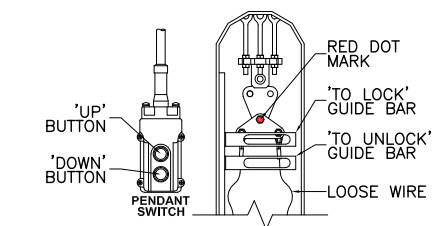

HEADFRAME & SERVICE DOOR - TO UNLOCK PROCESS

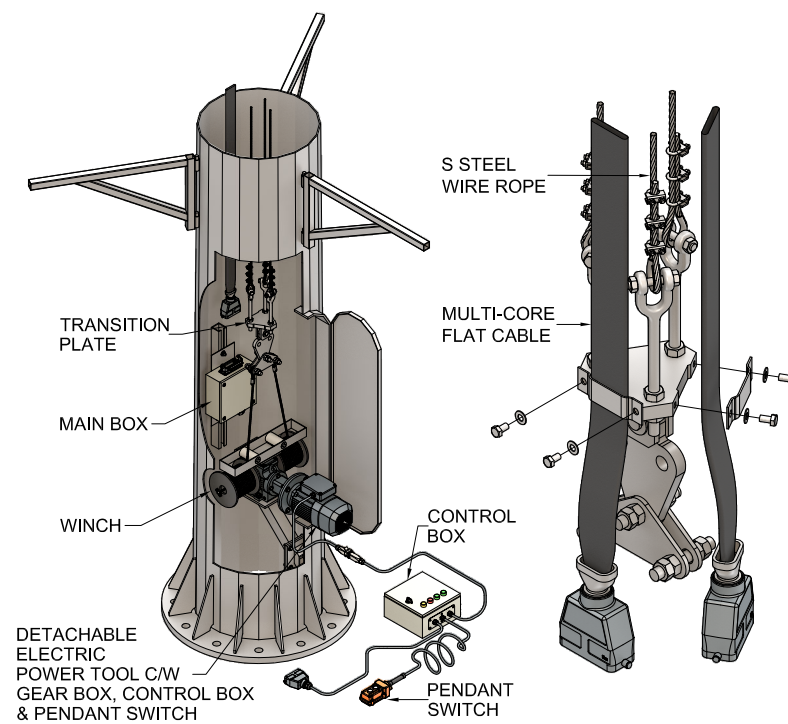

SERVICE DOOR COMPARTMENT

DETAIL A TRANSITION PLATE

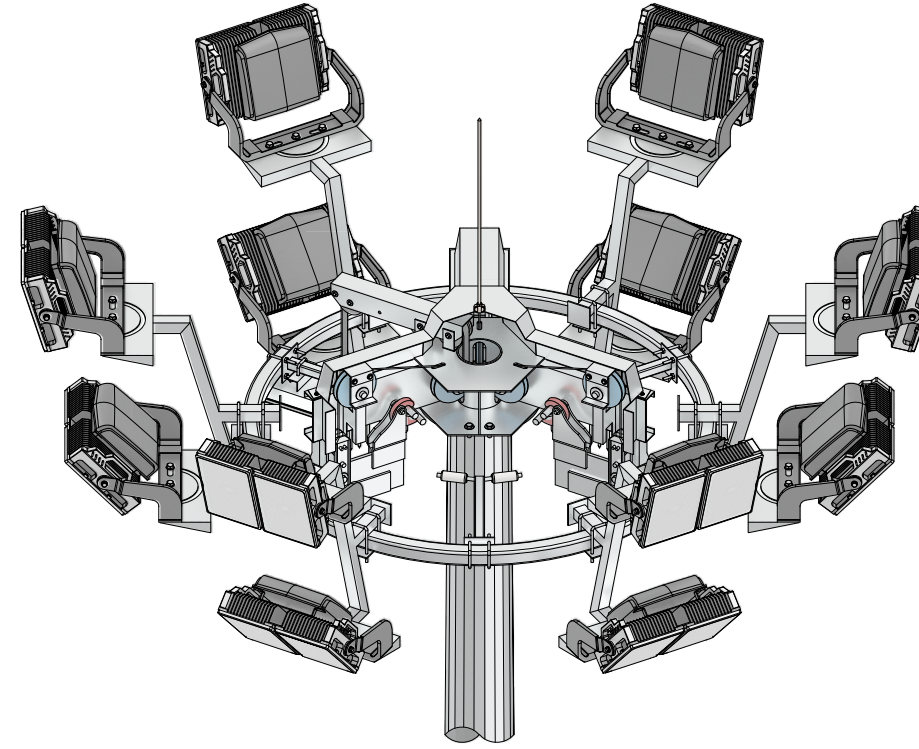

**HIGH MAST HEAD FRAME
 TYPICAL ARRANGEMENT OF LUMINAIRES**

NOTES :

THE LATCHING MECHANISM USES SELF LOCKING SYSTEM FULLY OPERATIONAL BY LAW OF GRAVITY AND MUST NOT CONTAIN MECHANICAL COMPONENTS SUCH AS SPRINGS, LEVERS ETC.

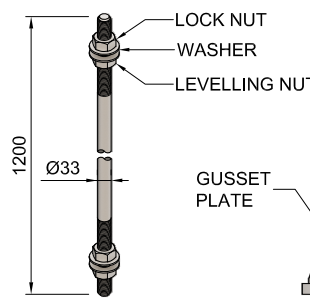

ANCHOR BOLT

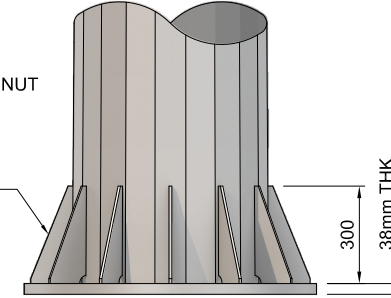

**BASE FLANGE (FRONT VIEW)
 STIFFENED WITH GUSSET PLATE**

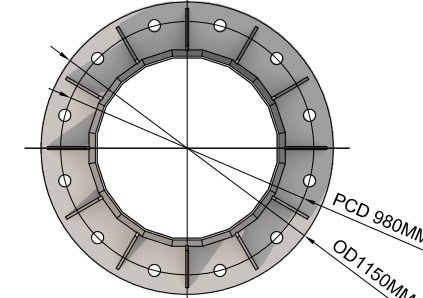

**BASE FLANGE (PLAN VIEW)
 STIFFENED WITH GUSSET PLATE**

SPECIFICATION

- 1) HIGH MAST DIMENSION
 - 1.1 MOUNTING HEIGHT = 25M
 - 1.2 CROSS SECTION SHAPE (NO OF SIDES) = 20
 - 1.3 MAX. TOTAL NO OF SECTIONS = 3
 - 1.4 MAX. SECTION LENGTH = 10.8M
- | | BOTTOM SECTION | INT. SECTION | TOP SECTION |
|-----------|----------------|--------------|-------------|
| LENGTH | 10800 | 10800 | 5000 |
| THICKNESS | 6 | 6 | 6 |
| TOP AF | | | 391 |
| BOTTOM AF | 738 | | |
- 1.5 SERVICE DOOR DIMENSIONS
 - 1.5.1 LENGTH = 1200mm
 - 1.5.2 WIDTH = 300mm
 - 1.5.3 DOOR BOTTOM FROM GROUND LEVEL = 600mm
 - 1.6 DOOR OPENING TO BE REINFORCED HEAVILY TO PREVENT BUCKLING = YES
 - 1.7 ANTI-VANDALISM DOOR LOCK = YES-TRIANGULAR DOOR LOCK
 - 1.8 BASE FLANGE
 - 1.8.1 OD = 980mm
 - 1.8.2 P.C.D = 1150mm
 - 1.8.3 THICKNESS = 38mm
 - 2) DESIGN CONDITIONS
 - 2.1 NUMBER OF LUMINAIRES = SUBJECT TO PROJECT
 - 2.2 LUMINAIRES RATING = SUBJECT TO PROJECT
 - 2.3 MAX. PROJECTED LUMINAIRE SAIL AREA (BASED ON SYMMETRICAL LUM. ARRANGEMENT) = 2.5MSQ
 - 2.4 MAX. LUMINAIRE AND BALLAST MASS = 800KGS
 - 2.5 BASIC WIND SPEED = 35 m/s at 10M HEIGHT
 - 2.6 DESIGN SAFETY FACTOR = SUBJECT TO PROJECT
 - 3) CONFIRMING STANDARDS
 - 3.1 MAST DESIGN = ILE TR7/ CP3
 - 3.2 MATERIAL = BS 4360 GR50A / JIS G3101 SS400
 - 3.3 WELDING (ELECTRIC ARC WELDING) = BS 5135
 - 3.4 GALVANIZING = BS EN ISO : 1461 (BS 729)
 - 4) TESTING PROCEDURES = DIMENSIONAL VERIFICATION GALVANIZING THICKNESS MATERIAL THICKNESS
 - 5) ULTIMATE GROUND REACTIONS
 - 5.1 UNFACTORED SHEAR FORCE =
 - 5.2 UNFACTORED OVERTURNING MOMENT =
 - 5.3 UNFACTORED AXIAL LOAD =

REV.	DATE	BY	DESCRIPTION

PROJECT

OWNER

M & E CONSULTANT

MAIN CONTRACTOR

DRAWING TITLE
**25M HIGH MAST
 HEAVY DUTY DESIGN**

MANUFACTURER

MESTRON ENGINEERING SDN BHD (591970-X)
 TEL: 603-8069 1815 FAX: 603-8069 1805
 EMAIL : info@mestron.com.my
 WEB : www.mestron.com.my



ISO 9001:2015

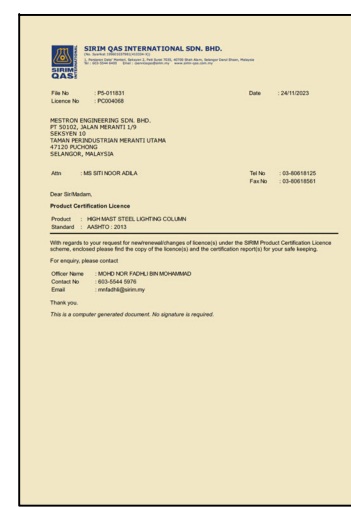

SIRIM PRODUCT CERTIFICATE



DRAWN BY : HAFIZ **DATE :** 31-03-2024

SCALE : N.T.S **CHKD. BY :** NED

DRAW NO. : 25M-HM-HD-24-D0-RO **REVISION**
 00